

C9GMMBNLK2

Categorie fornuis	90x60 cm
Aantal ovens met energielabel	1
Cavity heat source	Elektrisch
Type kookplaat	Gas
Type primaire oven	Thermogeventileerd
Reinigingssysteem primaire oven	Vapor Clean
EAN-code	8017709330996
Energie-efficiëntieklasse	A



Design



Esthetiek	Classici	Bedieningsknoppen	Smeg Classici
Series	Sinfonia	Kleur knoppen	Roestvrij staal
Design	Squadrato	Aantal bedieningsknoppen	8
Kleur	Matt Black	Kleur serigrafie	Zilver
Afwerking	Mat Zwart	Display	DigiScreen
Afwerking bedieningspaneel	Gekleurd plaatstaal	Deur	Met 2 horizontale stroken
Logo	Assembled st/steel	Type glas	Eclipse zwart glas
Positie logo	Strook onder de oven	Handgreep	Smeg Classici
Upstand	Ja	Kleur handgreep	Geborsteld roestvrijstaal
Kleur kookplaat	Roestvrij staal	Opbergruimte	Push pull
Type pannendragers	Gietijzer	Pootjes	Zilver
Type bediening	Bedieningsknoppen		

Programma's / functies

Aantal kookfuncties 9

Traditionele kookfuncties

 Statisch	 Geventileerd	 Circulaire
 ECO	 Kleine grill	 Grote vlak-grill
 Fan grill (large)	 Base	 Fan assisted base

Schoonmaak functie

 Vapor Clean

Overige functies

 Ontdooien

Technische specificaties kookplaat

UR

Totaal aantal kookzones 6

Linksvoor - Gas - 2URP (dual) - 4.20 kW

Linksachter - Gas - AUX - 1.00 kW

Middenvoor - Gas - AUX - 1.00 kW

Middenachter - Gas - SRD - 1.80 kW

Rechtsvoor - Gas - SRD - 1.80 kW

Rechtsachter - Gas - RP - 3.00 kW

Type gasbranders Standaard

Automatische
vonkontsteking Ja

Thermobeveiliging

Ja

Branderdeksels

Mat zwart geëmailleerd

Technische specificaties primaire oven



Aantal lampen 2

Aantal ventilatoren 2

Netto inhoud 115 l

Bruto inhoud 1e oven 129 l

Materiaal ovenruimte Ever Clean emaille

Aantal kookniveaus 5

Type ovenrekken Metalen zijsteunen

Soort verlichting Halogeen

Vermogen lamp 40 W

Instelling kooktijd Start en stop

Automatische Ja

inschakeling verlichting
bij openen deur

Deur openen naar beneden

Uitneembare ovendeur Ja

Volledig glazen Ja
binnendeur

Uitneembaar glas Ja

binnendeur

Aantal ruiten ovendeur 3

Aantal thermo- 2

reflecterende ruiten

Veiligheidsthermostaat Ja

Koelsysteem Mantelkoeling

Afmetingen bruikbare 371x724x418 mm

interne ovenruimte

(hxbxd)

Temperatuurregeling Elektro-mechanisch

Onderwarmte - 1700 W

vermogen

Bovenwarmte - 1200 W

vermogen

Grill - vermogen 1700 W

Grote vlakgrill - 2900 W

vermogen

Circulatie - vermogen 2 x 1550 W

Type grill Elektrisch

Opties primaire oven

Timer Ja

Minimum temperatuur 50 °C

Akoestisch signaal einde kooktijd Ja

Maximum temperatuur 260 °C

Meegeleverde accessoires primaire oven en kookplaat

Gietijzeren wokring	1	Bakplaat (40 mm)	1
Houder t.b.v. caffettiera	1	Inzetrooster	1
Rek met achter- en zijstop	1	Kerntemperatuurmeter	1
Bakplaat (20 mm)	1		

Elektrische aansluiting

Aansluitwaarde 3200 W
 Stroom 14 A
 Spanning 220-240 V
 Electric cable Installed, Single phase

Lengte voedingskabel 110 cm
 Frequentie 50/60 Hz
 Aansluitkast 3 polig

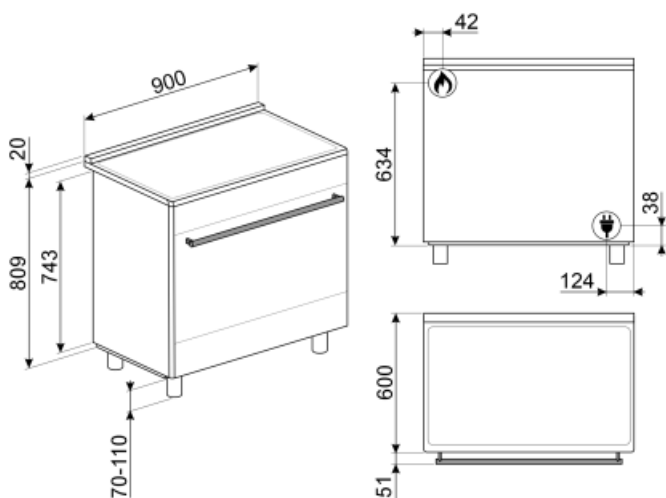

Accessoires niet inbegrepen



TPKTR9

Stainless steel teppanyaki plate, suitable for Victoria TR9, Master and Sinfonia cookers

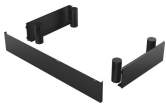

KITH95CPF9

Height extension kit with plinth, (950mm), three sides, black with feet, suitable for CPF9 Portofino and Sinfony C9 cookers



GTP

Gedeeltelijk uittrekbare telescopische geleiders (1 niveau)



BGTR9

Gietijzeren grillplaat geschikt voor 90 cm en 100 cm Victoria



KITPBX

Height reduction feet (850mm), st/steel, for Sinfonia and Master cookers (845-856mm)



BBQ9

BBQ

Dubbelzijdig



PALPZ

Pizzaschep met inklapbare handgreep breedte: 315 mm lengte: 325 mm

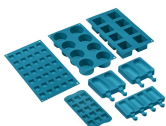

SMOLD

Set van 7 siliconen vormpjes voor ijsjes, ijslolly's, pralines, ijsblokjes of om etenswaren te portioneren. Bruikbaar van -60 ° C tot + 230 ° C



AIRFRY9

Air fryer rack AIRFRY . Ideal for recreating traditional frying in the oven, but with fewer calories and less fat. It allows you to cook quickly and simply dishes such as French fries, fried vegetables and fish, ensuring perfect browning and crispiness.



SFLK1

Kinderslot



PRTX

Ronde pizzasteen met handvaten, diameter 35 cm



PPR9

Refractory pizza stone without handles. Squared shaped stone: L64xH2,3xP37,5 cm Suitable also for gas ovens, to be put on the griddle.



KITH900CPF9

Plinth, 90cm, three sides, black, suitable for CPF9 Portofino or Sinfony C9 cookers



KITSB9MB

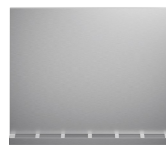

KITC9X9-1

















Spatscher, 90x75 cm, RVS, geschikt voor Portofino, Master en Sinfonia fornuizen













GTT

Volledig uittrekbare telescopische geleiders (1 niveau)

Symbols glossary (TT)

 <p>Heavy duty gietijzeren pannendragers: voor maximale stabiliteit en sterkte.</p>	 <p>A: Droogprestaties van het product, gemeten vanaf A +++ tot D / G afhankelijk van de productfamilie</p>
 <p>Installation in column: Installation in column</p>	 <p>Knobs control</p>
 <p>Luchtkoelsysteem: om een veilig oppervlak te garanderen temperaturen.</p>	 <p>Met de schakelaar op dit symbool is verwarming niet mogelijk, zelfs niet als de thermostaat wordt gedraaid.</p>
 <p>4.3 inch display with LED technology, usability with knobs + 3 touch keys</p>	 <p>Deuren met driedubbele beglazing: aantal glazen deuren.</p>
 <p>Geëmailleerde binnenkant: De geëmailleerde binnenkant van alle Smeg-ovens heeft een speciale antacidumvoering die helpt om de binnenkant schoon te houden door de hoeveelheid kookvet te verminderen.</p>	 <p>Fan assisted base: the mix of fan and lower heating element alone allows to finish cooking foods already cooked on the surface but not internally more quickly. This system is recommended to finish cooking foods that are already well cooked on the surface, but not internally, which therefore require a moderate higher heat. Ideal for any type of food.</p>
 <p>Ventilator met bovenste en onderste elementen: de elementen in combinatie met de ventilator zijn bedoeld om een meer gelijkmatige warmte te bieden, een methode die vergelijkbaar is met conventioneel koken, dus voorverwarmen is vereist. Het meest geschikt voor items die langzaam koken vereisen.</p>	 <p>De ovenruimte wordt tegelijk door het onder- en bovenelement verwarmt. De hitteverdeling over het gerecht is afhankelijk van het niveau waarop men dit plaatst. Geschikt voor bakken op 1 niveau. Gerechten: alle ovenschotels, vlees, gevogelte, brood, (gevulde) taarten. Speciaal: gans en eend (bevatten veel vet).</p>
 <p>De ovenruimte wordt uitsluitend verhit door het onderelement. Voor gerechten die een hoge basistemperatuur behoeven, heeft deze bakstand weinig tot geen invloed op de korst aan de bovenzijde. Geschikt voor bakken op 1 niveau, ideaal voor deeggerechten die moeten rijzen (bijv. pizza). Bij gevulde taarten zal de deegbodem beter droog blijven.</p>	 <p>Circulaire: it is the perfect function for cooking all types of dishes in a more delicate way. The heat comes from the back of the oven and is distributed quickly and evenly The fan is active. It is also ideal for cooking on multiple levels without mixing smells and flavors.</p>
 <p>ECO: low energy consumption cooking: this function is particularly suitable for cooking on a single shelf with low energy consumption. It is recommended for all types of food except those that can generate a lot of moisture (for example vegetables). To achieve maximum energy savings and reduce time, it is recommended to put the food in the oven without preheating the cooking compartment</p>	 <p>De warmte wordt geproduceerd door het grill- en bovenelement. Verhitting over het volledige oppervlak. De thermostaat wordt, afhankelijk van het gerecht, in de regel op de maximale stand gezet. Bij een korte baktijd kan de oven deur gesloten blijven; bij langere baktijd blijft deze gedeeltelijk geopend. Voor vleesgerechten (klein- en middelgroot), vleespennen, vis, groenten, gratineren etc.</p>

-  De warmte is alleen afkomstig van het grill-element. Verhitting over een kleiner oppervlak. Te gebruiken als de grote vlak-grill, maar voor kleinere hoeveelheden
-  Gas ovens offer instantaneous heat control, reduced cooking times and the ability to bake at much lower temperatures than electric ovens.
-  The inner door glass: can be removed with a few quick movements for cleaning.
-  Automatic opening: some models have Automatic opening door when the cycle is finished which is a perfect solution for handle-less kitchen units as no handle is needed. For safety reasons, the door locks automatically when the machine is in use to avoid it being opened inadvertently.
-  Ultrasnelle branders: Krachtige ultrasnelle branders bieden tot 5kw vermogen.
-  The capacity indicates the amount of usable space in the oven cavity in litres.
-  Ventilator met grillelement: De ventilator vermindert de felle hitte van de grill en biedt een uitstekende methode om verschillende soorten voedsel, karbonades, steaks, worstjes enz. Te grillen, waardoor het gelijkmatig bruin wordt en de warmte wordt verdeeld, zonder het voedsel uit te drogen. De bovenste twee niveaus die voor gebruik worden aanbevolen, en het onderste deel van de oven kunnen worden gebruikt om gerechten tegelijkertijd warm te houden, een uitstekende mogelijkheid bij het bereiden van een gegrild ontbijt. Halve grill (alleen middengedeelte) is ideaal voor kleine hoeveelheden voedsel.
-  All glass inner door: All glass inner door, a single flat surface which is simple to keep clean.
-  verlichting
-  The oven cavity has 5 different cooking levels.
-  Vapor Clean: a simple cleaning function using steam to loosen deposits in the oven cavity.

Benefit (TT)

True-convection

The best cooking performances guaranteed by ventilated circular flow

Multiple fans and heating elements guarantee the perfect aerodynamic heat flow, allowing homogeneous and quicker cooking inside the cavity.

Gas hob

Gas provides permanent control of the heat source and the temperature change is immediate

Equipped with a thermocouple, the gas supply is cut off if the flame is extinguished for greater safety.

Vapor Clean

By inserting water into a recess at the bottom of the cavity, steam is generated, which softens the residue and facilitates its removal

By inserting water into a recess at the bottom of the cavity, steam is generated, which softens the residue and facilitates its removal.

Touch control

Easy and intuitive timer setting with a single touch

Isothermic Cavity

The best cooking performance at the highest energy efficiency

Double Turbine

The oven has two fans equipped with two circular heating elements allowing cooking with rotating heat

Tangential cooling

New cooling system with tangential fan and airflow from the door to the splashback

Multilevel halogen light

Internal halogen lighting on different levels guarantees excellent visibility

Adjustable height

Cooker top flushed with the working area thanks to adjustable feet

Removable inner glass

Internal door glasses are easily removable for complete cleaning

Multilevel cooking

Several cooking levels allow maximum flexibility of use

Cold door

During any function, the external door glass is cold, avoiding any risk of burns

AirFry (AIRFRY optional accessory)

Lighter and tastier food thanks to airfry basket (optional accessory)

BBQ (optional accessory)

Barbeque cooking directly in the oven with the double-sided grill (BBQ optional accessory)

Pizza stone (optional accessory)

Baking with refractory stone for soft and crispy pizza and yeast products (STONE optional accessory)

Push-pull storage compartment

More space thanks to the lower push-pull compartment, ideal for storing accessories or cooking utensils